

J14	Description
Short	Default upgrade mode on power-up, boot time: 350 ms. Suitable for products without strict power-on timing requirements.
open	Normal operation mode on power-up, boot time: 350 ms. Short the test pads during power-up to enter upgrade mode. Intended for products with strict power-on timing requirements.

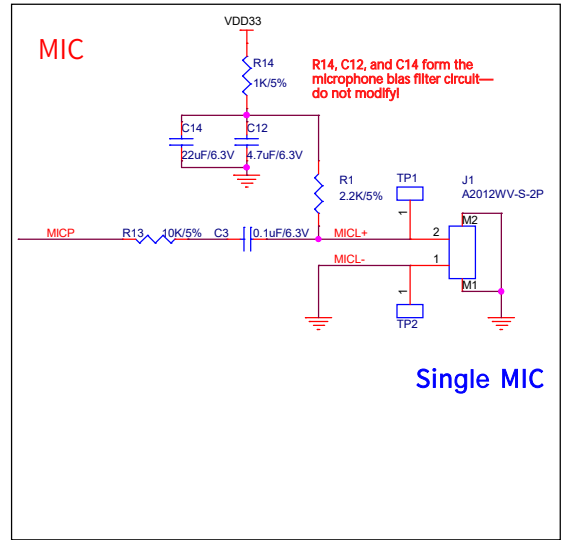

Single MIC

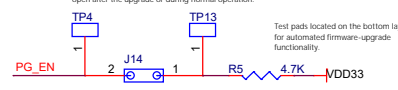
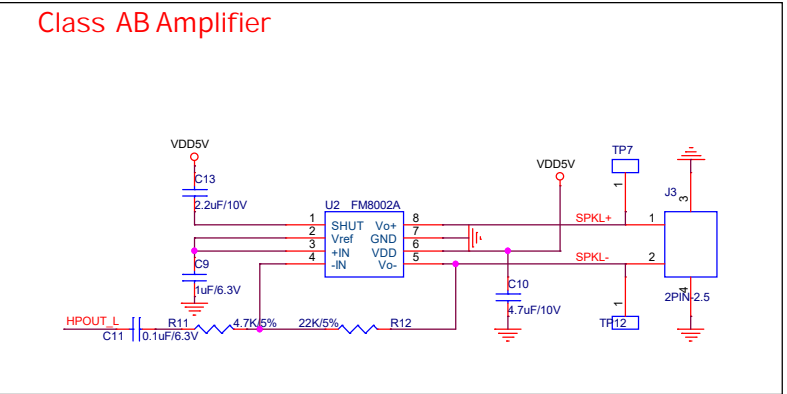
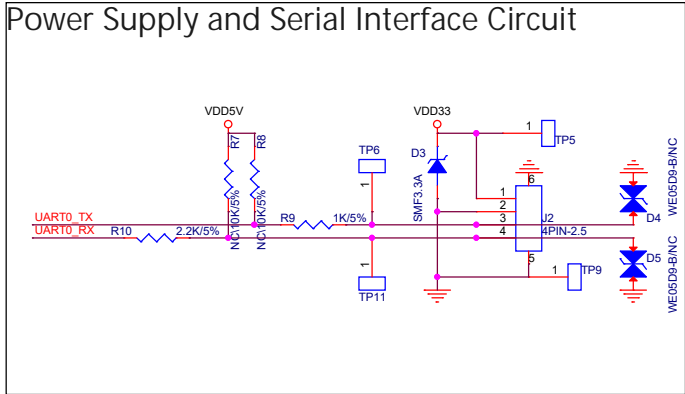

### CI1308XV Application Reference Design

Sheet Title = 02:Typical application		
Title		
Size	Document Number	Rev
Date: Tuesday, July 22, 2025	Sheet 3 of 3	1