

**ChipIntelli**  
成都启英泰伦科技有限公司  
Chipintelli Technology Co.,Ltd.

Name: CI1316X Low power reference design

Features: single-mic differential input and speaker output

Applications: Genetal products

More info: <https://aiplatform.chipintelli.com>

Release date :

Note: It is important that during both the application design and design verification stages, customers carefully read the application notes and design considerations provided in the reference design schematics, and maintain close communication with our FAE team.

Sheet Title = 00.Front Cover		ChipIntelli 成都启英泰伦科技有限公司 CHIPINTELLI TECHNOLOGY CO.,LTD.	
Title			
Size B			
Document Number		Rev	
<Doc>		1.0	
Date: Thursday, August 15, 2024		Sheet 1 of 3	

版本	修改记录	作者
V1.0	初版	启英泰伦

Sheet Title = 01.Revision History		 成都启英泰伦科技有限公司 ChipIntelli Technology Co., Ltd.	
Title			
Size A	Document Number <Doc>		Rev 1.0
Date:	Thursday, August 15, 2024	Sheet	2 of 3

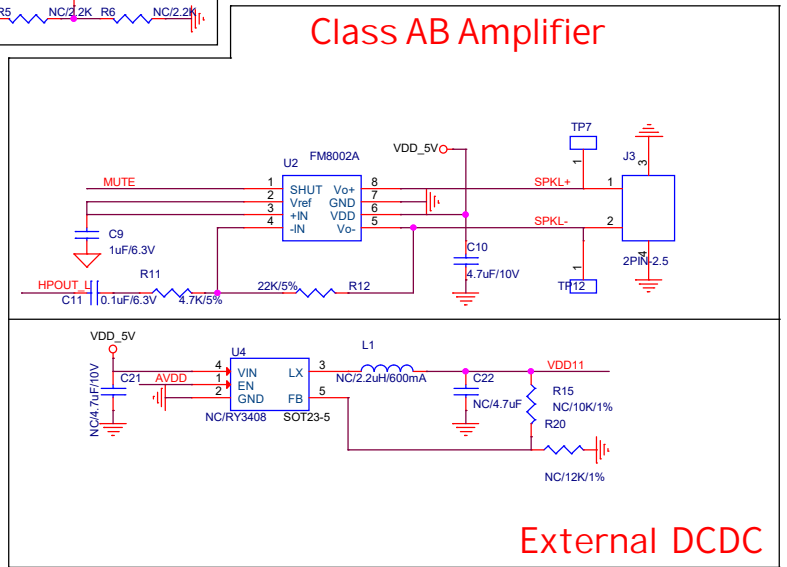
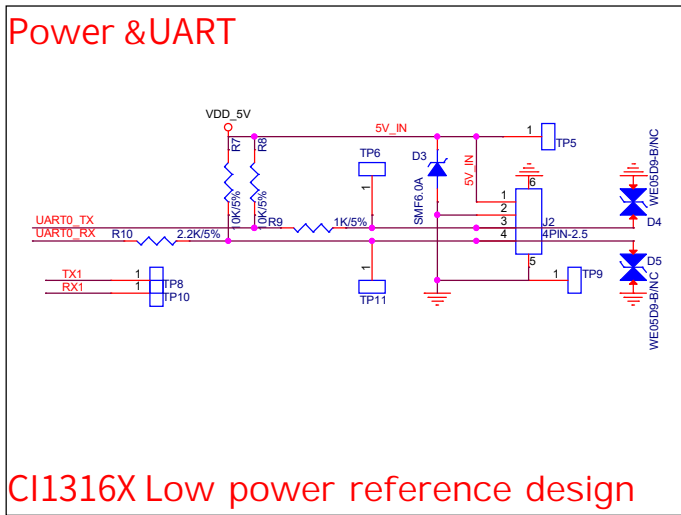
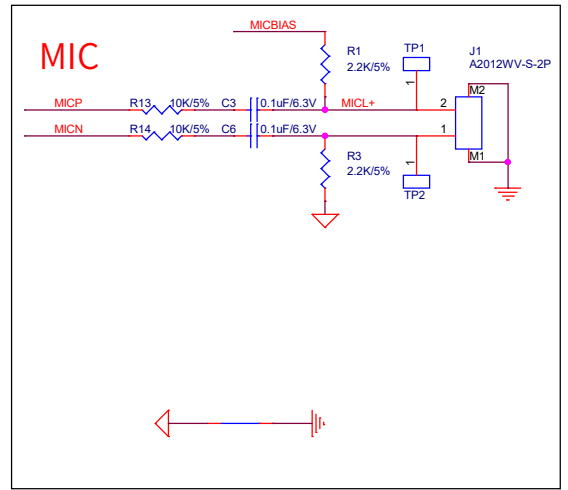
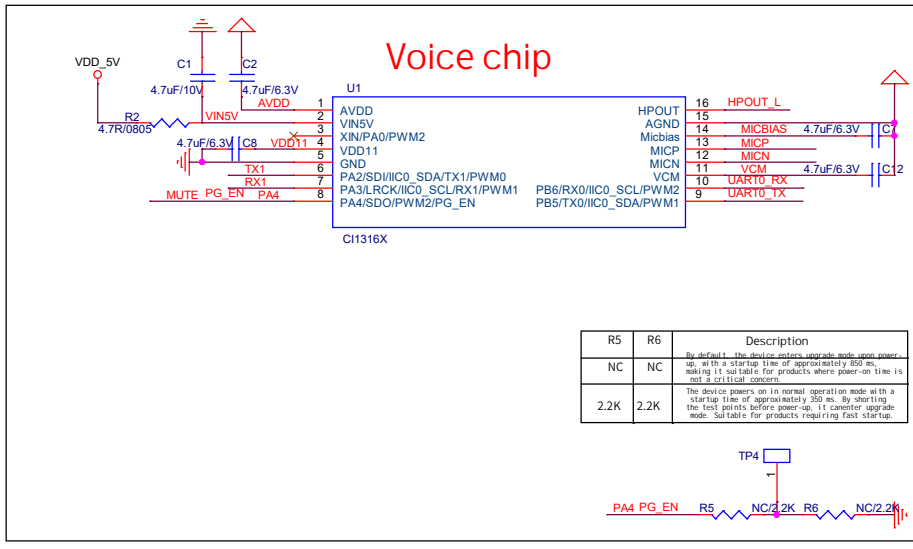

CI1316X Low power reference design

External DCDC

Sheet Title = 02:Typical application

Title		
Size	Document Number	Rev
Date:	Thursday, August 15, 2024	Sheet 3 of 3