

ChipIntelli
成都启英泰伦科技有限公司
Chipintelli Technology Co.,Ltd.

Name: CI1316X Low Cost Reference Design

Feature: single-mic differential input, speaker output

Application: Suitable for general-purpose products, with single-microphone input, voice playback, and compatible with wave soldering process.

More info: <https://aiplatform.chipintelli.com>

Release date:

Note: It is important that during both the application design and design verification stages, customers carefully read the application notes and design considerations provided in the reference design schematics, and maintain close communication with our FAE team.

Sheet Title = 00.Front Cover			ChipIntelli 成都启英泰伦科技有限公司 CHIPINTELLI TECHNOLOGY CO.,LTD.	
Title				
Size	Document Number			Rev
B	<Doc>			1.0
Date:	Thursday, August 15, 2024	Sheet	1	of 3

版本	修改记录	作者
V1.0	初版	启英泰伦

Sheet Title = 01.Revision History		 成都启英泰伦科技有限公司 ChipIntelli Technology Co., Ltd.	
Title			
Size A	Document Number <Doc>		Rev 1.0
Date:	Thursday, August 15, 2024	Sheet	2 of 3

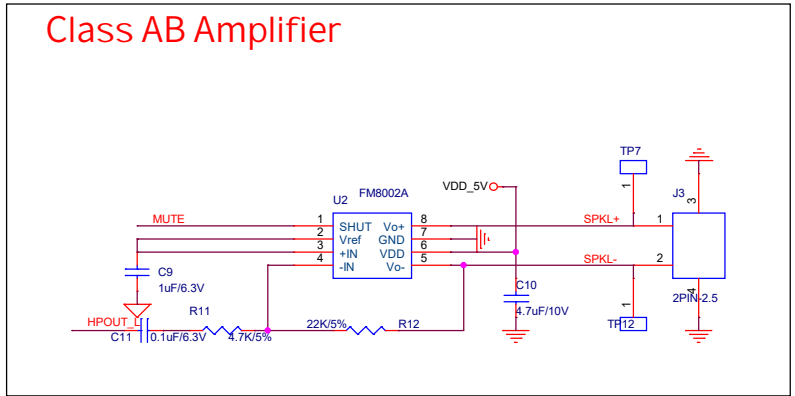
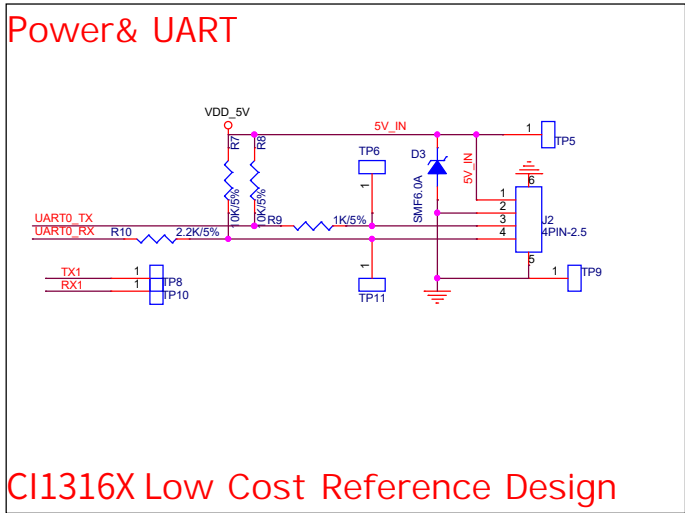
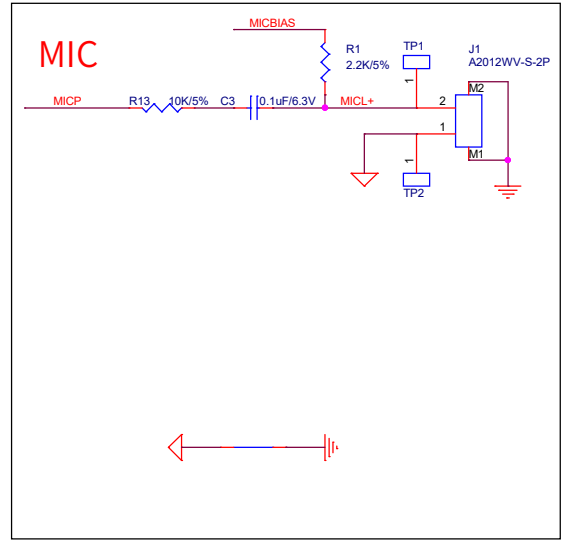
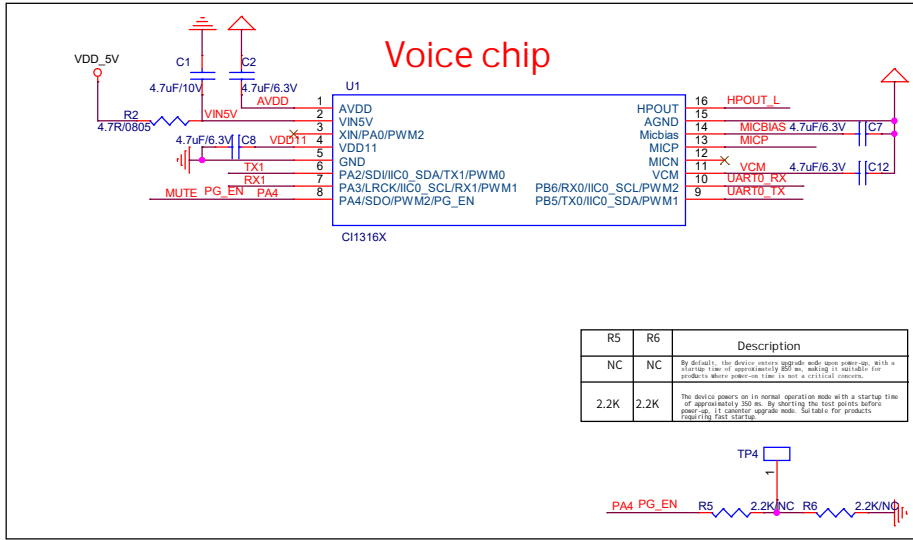

CI1316X Low Cost Reference Design

Sheet Title = 02:Typical application		
Title		
Size	Document Number	Rev
Date: Thursday, August 15, 2024	Sheet 3 of 3	2