

**ChipIntelli**  
成都启英泰伦科技有限公司  
Chipintelli Technology Co.,Ltd.

Name: CI1316X high reliability reference design

Features: sinle-mic differential input, voice prompt output

Applications: general, Suitable for general-purpose products, with single-microphone input, voice playback, and compatible with wave soldering process.

More info: <https://aiplatform.chipintelli.com>

Release date:

Note: It is important that during both the application design and design verification stages, customers carefully read the application notes and design considerations provided in the reference design schematics, and maintain close communication with our FAE team.

Sheet Title = 00.Front Cover		ChipIntelli 成都启英泰伦科技有限公司 CHIPINTELLI TECHNOLOGY CO.,LTD.	
Title			
Size B			
Document Number		Rev	
<Doc>		1.0	
Date: Thursday, August 15, 2024		Sheet 1 of 3	

版本	修改记录	作者
V1.0	初版	启英泰伦

Sheet Title = 01.Revision History		 成都启英泰伦科技有限公司 ChipIntelli Technology Co., Ltd.	
Title			
Size A	Document Number <Doc>		Rev 1.0
Date:	Thursday, August 15, 2024	Sheet	2 of 3

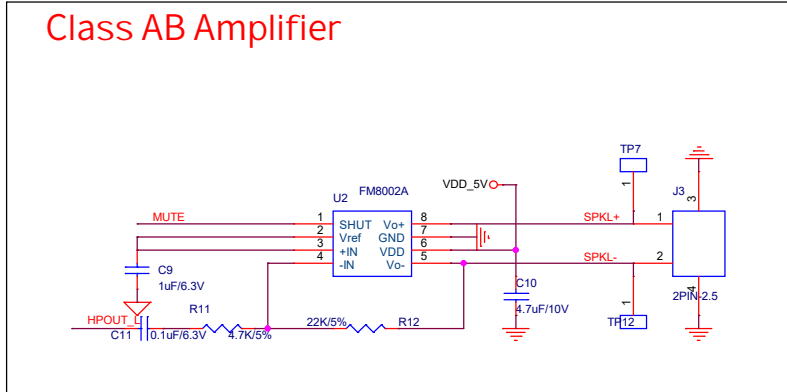
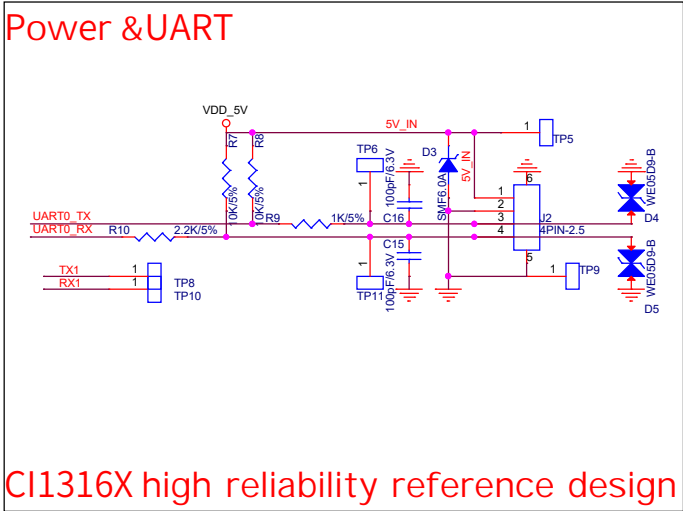
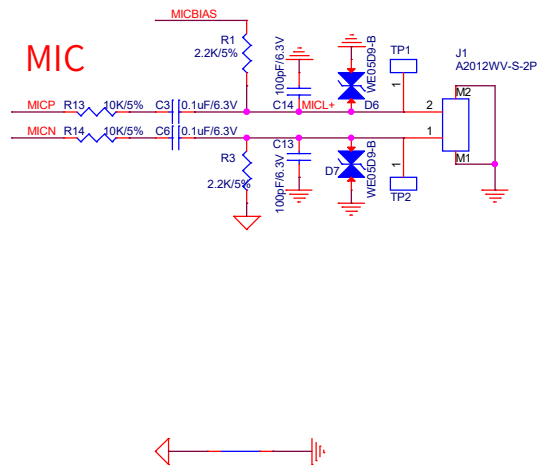
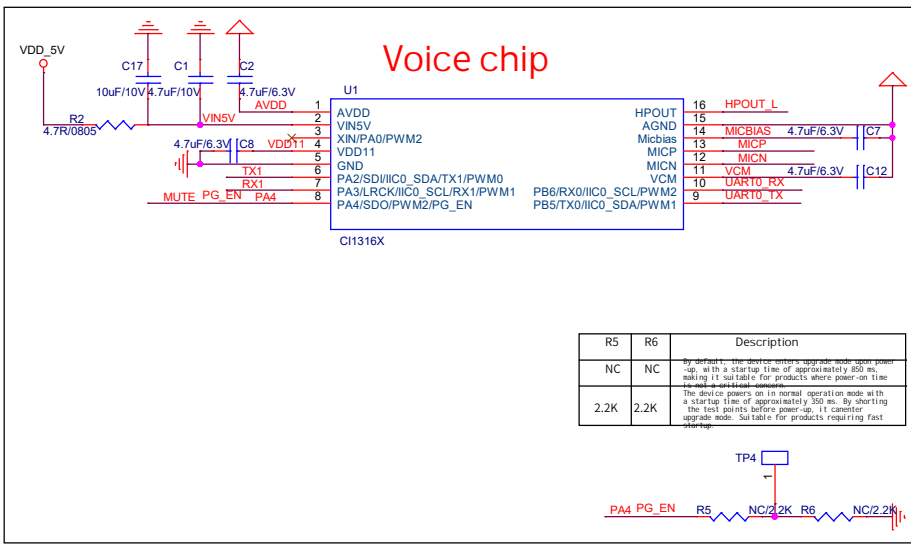

C11316X high reliability reference design

Sheet Title = 02:Typical application		
Title		
Size	Document Number	Rev
Date:	Thursday, August 15, 2024	Sheet 3 of 3