



Name: CI1332X Low power reference design

Features: CI1332X single-mic differential input, voice prompt output

Application: Suitable for products with requirement on single-mic differential input, voice prompt output

More info: <https://document.chipintelli.com>

Release date:

Note: It is important that during both the application design and design verification stages, customers carefully read the application notes and design considerations provided in the reference design schematics, and maintain close communication with our FAE team.

 成都启英泰伦科技有限公司 Chipintelli Technology Co., Ltd.		
Title : Front Cover		
Size B	Document Number <Doc>	Rev 1.3
Date:	Wednesday, October 16, 2024	Sheet 1 of 3

版本	修改记录	作者
V1.0	初版	启英泰伦

Voice Chip

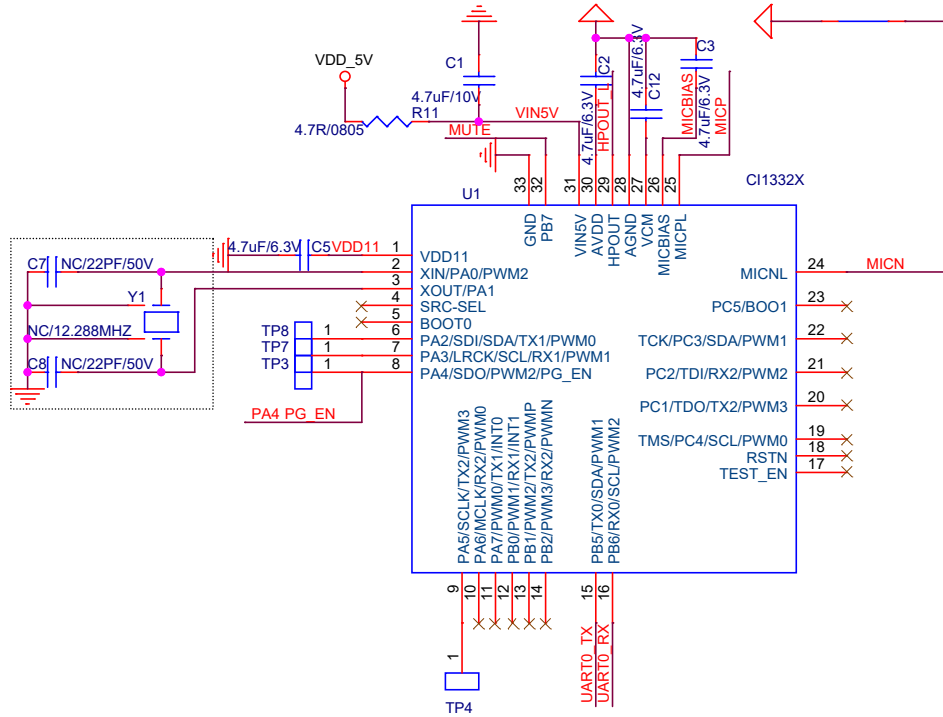

MIC

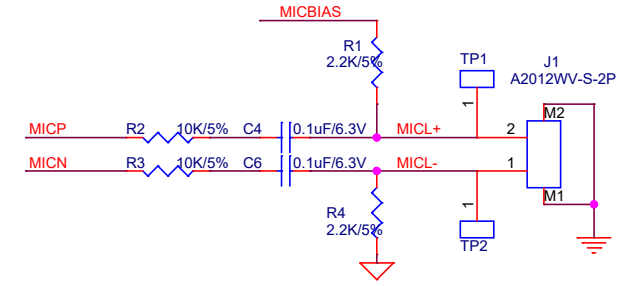

Class AB Amplifier

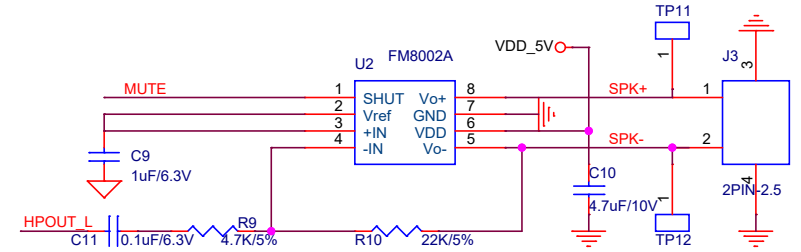

Power & UART

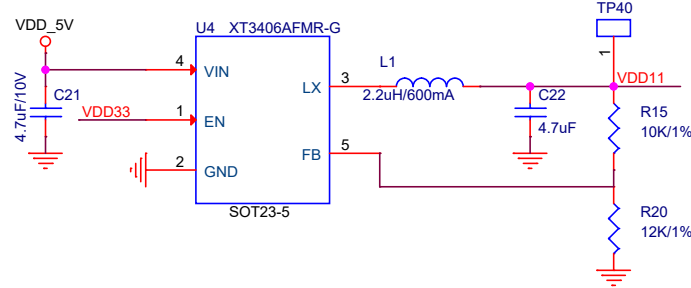
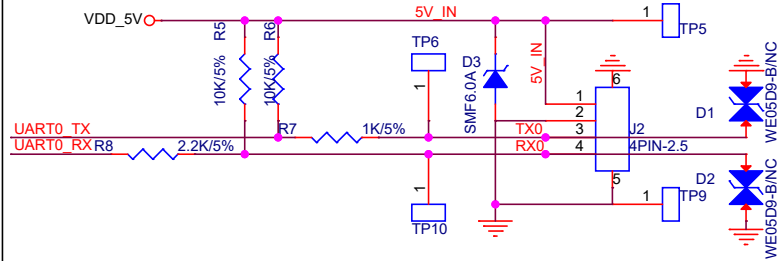

R12	R13	
NC	NC	
2.2K	2.2K	

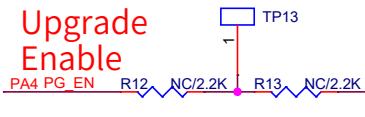

Chipintelli 成都高思泰电子科技有限公司
Chipintelli Technology Co., Ltd.

Title :Low Power application

Size Custom	Document Number <Doc>	Rev 1.0
-------------	-----------------------	---------

Date: Wednesday, October 16, 2024 Sheet 3 of 3

CI1332X low power reference design