

Voice chip

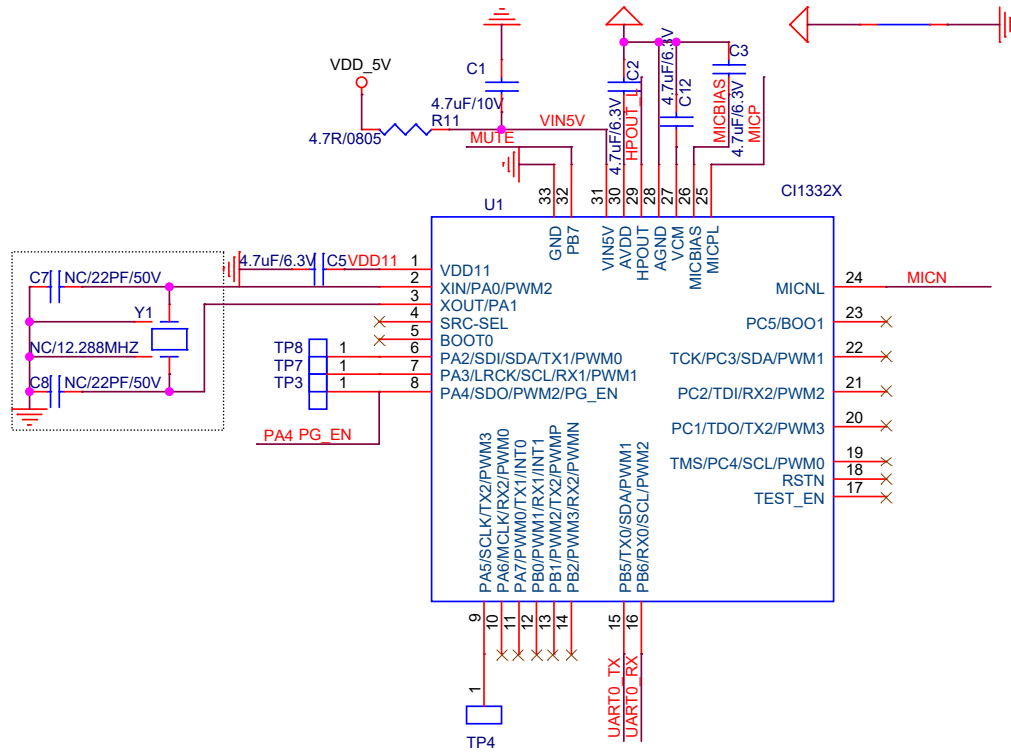

MIC

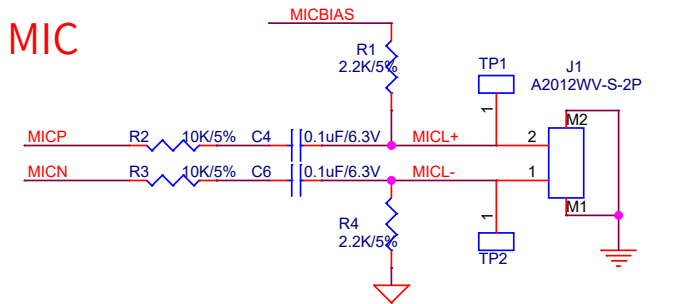

Upgrade Enable

R12	R13	Description
NC	NC	Upon power-on, the system enters upgrade mode immediately. The external upgrade signal is detected on the upgrade pin at this time, the upgrade process will begin. The startup time is approximately 100ms, which is suitable for applications with slow start requirements.
2.2K	2.2K	Upon power-on, the system enters normal startup mode, suitable for applications requiring fast boot. The power-on startup time is approximately 20ms.

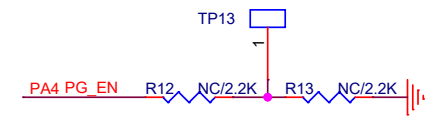

Power & UART

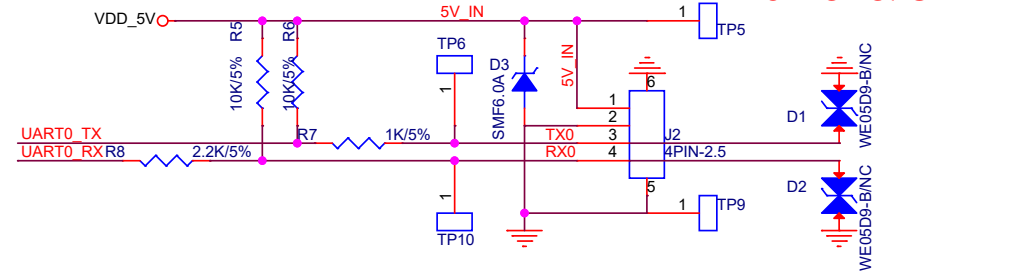

Class AB Amplifier

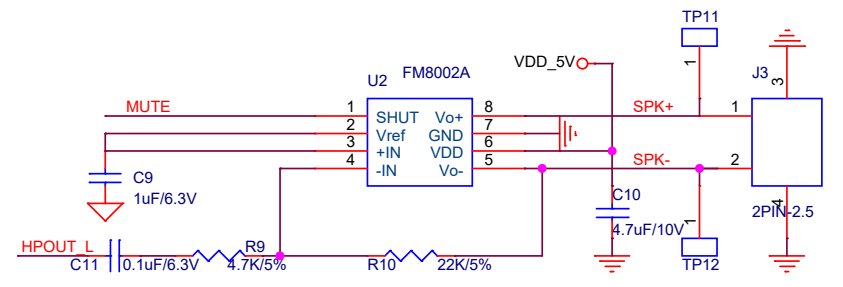

CI1332X Standard Reference Design